



WINEKEEP WINE LOCKERS



The Wine Locker

The WineKeep Wine Locker brings upscale wine storage and aging capabilities to the caring wine connoisseur. Its temperature and optional moisture controlled environment assures that the wine sleeps in a perfect aging environment that will astound not only the owner but also the owner's guests.

WineKeep Wine Lockers come in many standard sizes as pre-designed packages or can be ordered to meet a customer's specific design needs with no added inconvenience. Each Wine Locker is shipped knocked down as panels. Once on location, they can easily be assembled using a single cam action panel locking tool. Environmental control equipment can be delivered preassembled, self-contained or unassembled for installations by a local HVAC or refrigeration contractor.

Offering over 20 different metal colors, the Wine Locker can be designed to blend in or become the focal point of any room. Wine Lockers can also be custom finished on-site with various exotic wood planking, stone or other materials to give any type of look desired.

CALL FOR A DEALER NEAR YOU!

Energy Efficient Wine Storage Rooms

All Wine Lockers come with highly insulated panels that meet stringent government standards and come with UL and NSF listings. All panels also meet the new government EISA energy requirements regulating rooms 55° and below. By utilizing the highest quality materials, WineKeep's manufactured rooms provide the ultimate in flexible design configuration, quality, and ease of assembly. Each panel comes with a ten year limited warranty assuring you will have many years of reliable service from your unit.



Providing all your wine storage solutions.

Wine Locker Kit Includes:

Storage room: Each Wine Locker package consists of wall panels, ceiling panels, lockable glass entry door and environmental control unit. All panels are equipped with cam-action locking devices to easily connect each pane together for installation. Panels are manufactured with a 4" insulation core bonded between inner and outer beautifully painted metal skins. Standard interior and exterior metal is black. Several other custom finishes are available.

Wine Room Sizes:

	Nominal Size
6'2" x 4'8" x 7'6"	(6'x5')
5'10" x 7'10" x 7'6"	(6'x8')
7'10" x 7'10" x 7'6"	(8'x8')
7'10" x 9' 9 1/2" x 7'6"	(8'x10')
9'9 1/2" x 9'9 1/2" x 7'6"	(10'x10')
Custom sizes available.	

Storage Racks: Several wine rack packages available to choose from to fit any size room.

Cooling Unit: Medium temperature cooling unit. Optional humidity controls available.

Standard Wine Locker Drawing

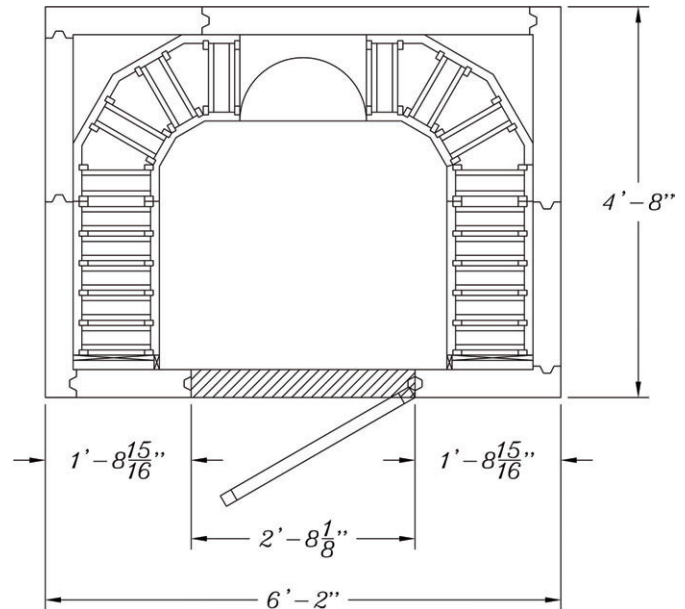

Our Service Commitment

At WineKeep, our goal is to develop lasting relationships with our customers, beginning with the very first telephone call. From the beginning, each customer is assigned a personal sales representative to assist them in every aspect of the sale. We strive to provide the best in sales and service, from quote to product delivery, with the emphasis on meeting our customers' needs better than anyone else. To help ensure our customers complete satisfaction, our customer service representatives are here to address any specific concerns which may arise following product shipment.

